

Mini Maintenance Kit

Part #:
PJDI900MINI-LS
DM11F - 11 GPM



GENUINE
DOSATRON
PARTS

1-800-523-8499
www.dosatronusa.com



Kit Contents:

J009:
Plunger seal



PDI729: Check Valve Cone



JD1105:
Check Valve Cone O-ring



PDI739: Top Guide



MDI358: Check Valve Spring



DOSA-LUBE:
Silicone



Use **Dosa-Lube** on specified parts only.



CAUTION: Parts may contain concentrated chemicals. The use of Proper Protective Equipment is recommended when performing maintenance.

Instructions

(Parts included in kit noted in blue)

Disassembly

1. Unscrew hose nut (PDI735) and remove the hose.

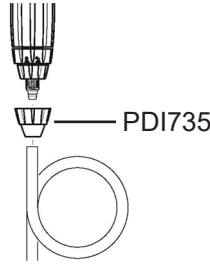

2. Unscrew injection stem assembly nut (PDI702) and pull down on the injection stem (PPDI045) to detach from the blue body, and set aside.

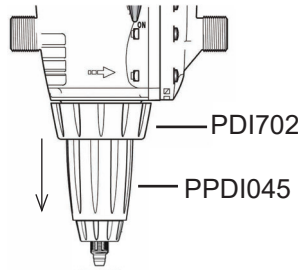

3. Remove the plunger (PDI848) by giving it 1/4 turn counter clockwise to unlock, then pull it down. Remove and discard the plunger seal (J009).

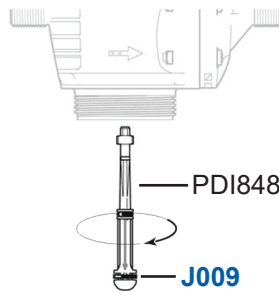

4. Remove the isolation body (PDI846) by pulling on it and place it in the solution.

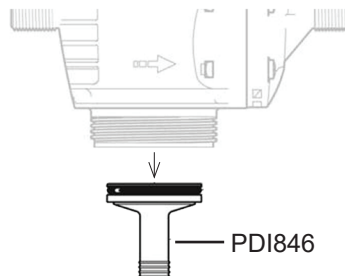

5. Unscrew the check valve nut (PDI734) and remove the check valve assembly (PJDI115), from the injection stem assembly (PPDI045), by pulling it down.

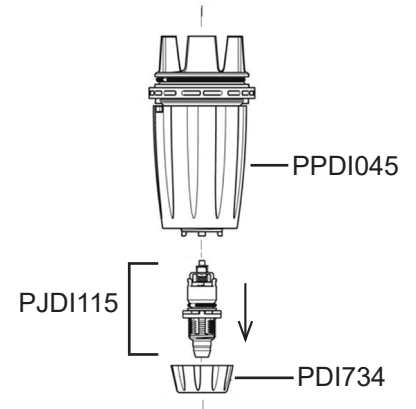

6. Remove the top guide (PDI739) from the check valve assembly (PJDI115), by giving it 1/4 turn counter clockwise. Discard the top guide (PDI739), check valve spring (MDI358), check valve cone (PDI729) and check valve cone o-ring (JD1105).

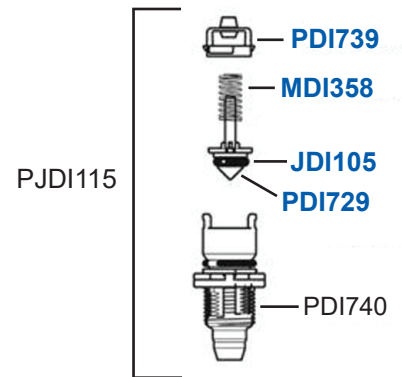

NOTE: Reassembly instructions on back.

Reassembly

7. Using the packet of **Dosa-Lube** provided in the kit, rub a small amount on the isolation body o-ring (8J040) and reinstall the isolation body (PDI846) back into the blue body by firmly pushing it in place.

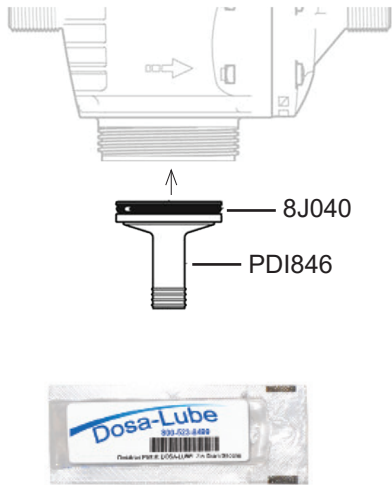

8. Take the new plunger seal (**J009**) and place it on the groove of the plunger (PDI848). Reinsert the plunger (PDI848) into the blue body through the opening of the isolation body, making sure the tip of the plunger lines up with the opening in the retainer, then give it 1/4 turn clockwise to lock into place.

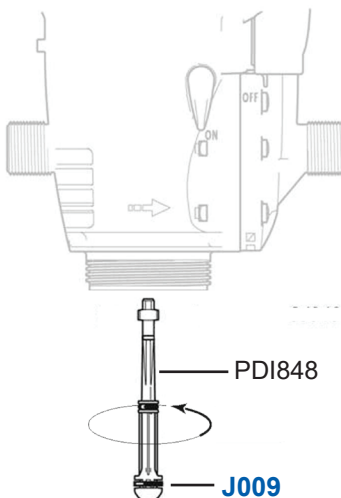

NOTE: Do not apply **Dosa-Lube** to the plunger seal (**J009**).

9. Take the new check valve cone (**PDI729**) and install the new check valve cone o-ring (**JDI105**). Insert the cone part going down into the check valve barb (PDI740). Place the new check valve spring (**MDI358**) on the rod of the check valve cone (**PDI729**), then attach the new top guide (**PDI739**), pushing it down and turning 1/4 clockwise until it locks.

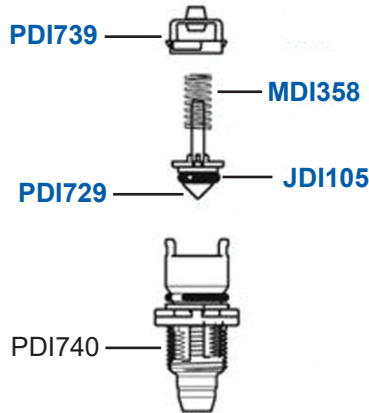

NOTE: Do not apply **Dosa-Lube** inside the check valve.

10. Rub a small amount of **Dosa-Lube** on the check valve barb o-ring (JDI130) only, then insert the check valve assembly (PDI740) back into the bottom of the injection stem assembly (PPDI045), make sure the 4 white keys on the bottom of the stem lock into the 4 black keys on the check valve. Screw the check valve nut (PDI734) back on.

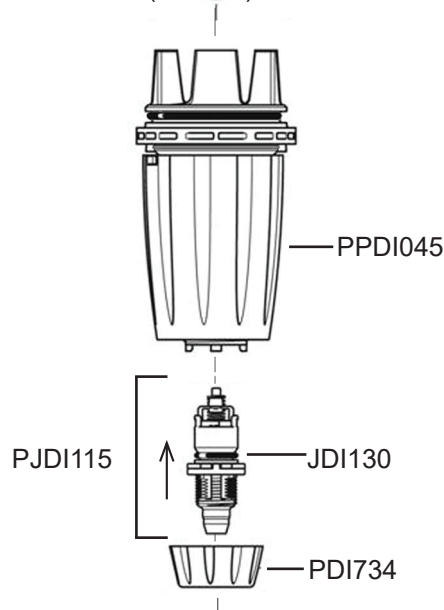

11. Lubricate the large o-ring (JDI100) on top of the injection stem assembly (PPDI045), with a small amount of **Dosa-Lube**. Insert the injection stem assembly back into the bottom of the blue body and screw back the the stem assembly nut (PDI702).

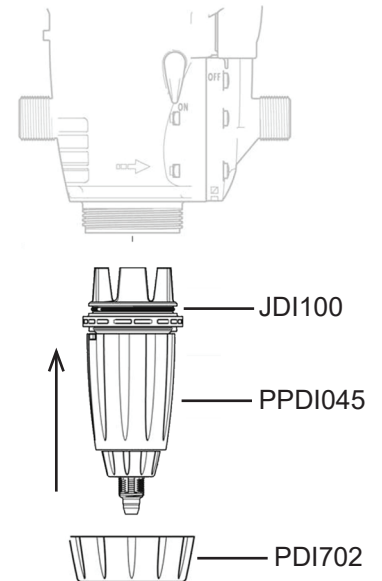

12. Cut 1" off from the top of the suction hose to ensure a tight fit, make sure to cut in a straight line. Attach the hose and the hose nut (PDI735) back to the unit.

